

ITEM	QTY	DESCRIPTION
1	1	CAP (TM36-2)
2	1	PACKING (TM36-2)
3	1	RING
3A	1	RING (LARGER SIZE)(TM36-2)
4	2	SCREW
5	1	E-CLIP
6	1	CAP
7	2	SCREW, TOP CAP
8	1	ADJUSTER
9	1	NUT, ADJUSTER
10	1	GASKET, TOP CAP
10A	1	GASKET, TOP CAP (TM36-2)
11	1	SCREW, IDLE ADJUSTER
12	1	SPRING, IDLE ADJUSTER
13	1	O-RING, IDLE ADJUSTER
14	1	AIR SCREW
15	1	SPRING, AIR SCREW
16	1	WASHER, AIR SCREW
17	1	O-RING, AIR SCREW
18	1	GASKET, BOWL
19	2	CAP, FLOAT
20	1	FLOAT VALVE ASSY 3.3
21	4	SCREWS, BOWL
22	1	SCREW
23	1	O-RING

MK-TM32-36

APPLICATIONS:
MIKUNI TM32-1
MIKUNI TM34-2
MIKUNI TM36-2

1985-1992 SUZUKI LTR250R ATV

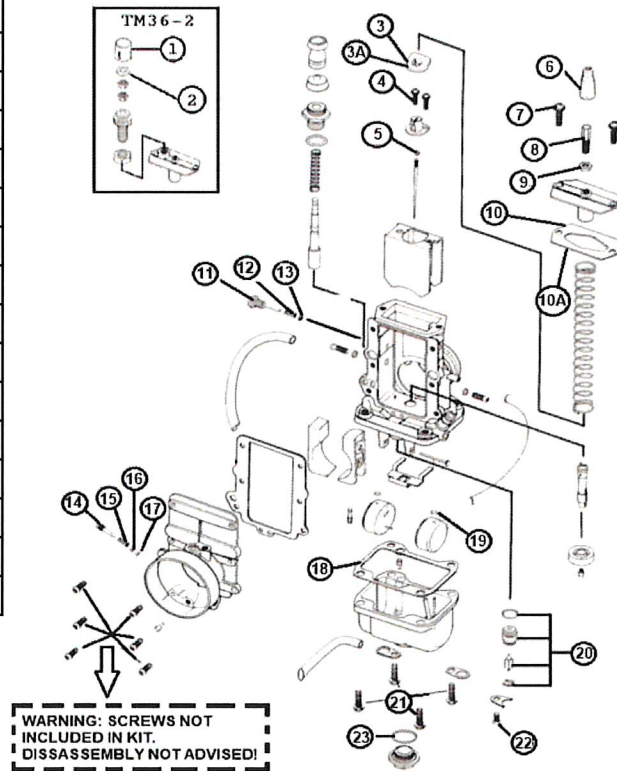

NOTE:

This kit does not include main jets or pilot jets. If needed, refer to the following Mikuni Part numbers when acquiring these jets:

Main Jet: 4/042-XXXX

Pilot Jet: VM22/210-XXXX

MIKUNI AMERICAN CORPORATION

www.mikunipower.com

HEAD OFFICE: 8910 MIKUNI AVENUE
 NORTHRIDGE, CALIFORNIA 91324-3496
 PHONES: (818) 885-1242
 FAX: (818) 993-7387/8